

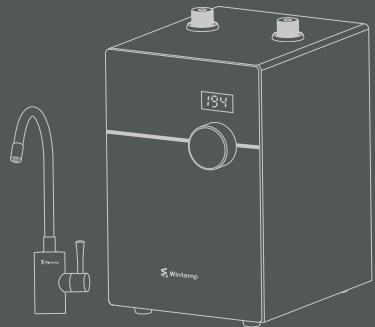

Installation & Operation Manual

Instant Hot Water Dispenser



SKU No.: B25AU-FHB

CONTENTS

Warnings	02
Package Contents	04
Complete Assembly View	05
Technical Specifications	06
Before Installation	07
Installation Guide	07
First Time Use Instructions	12
Function & Operation Guide	12
Faucet Use Guide	13
Maintenance	13
Troubleshooting Guide	14
Important Use Notes	16
Warranty & Service Information	16

Thank You for Choosing WINTEMP!

Thank you for choosing the WINTEMP under-counter instant hot water dispenser. We appreciate your trust and are pleased to bring convenience, comfort, and quality to your daily kitchen routine.

For the best experience, please follow the step-by-step instructions in this manual. When installed and used correctly, this system provides convenient near-boiling water for beverages, cooking preparation, and everyday kitchen use.

Warnings

1. Scalding Hazard

This product dispenses very hot water, and direct contact with hot water may cause serious burns or scalding. Keep children away from the faucet and hot water outlet, and do not allow children to operate the product without adult supervision. Always operate the faucet carefully, keep hands, face, and body away from the hot water stream, and use only cups, containers, or cookware that can safely withstand very hot water.

2. Electrical Safety Hazard

This appliance must be properly grounded and installed within reach of a grounded electrical outlet. For the U.S. market, a properly grounded GFCI outlet is recommended under the sink. Do not use the unit if the power cord, plug, outlet, or appliance appears damaged, and do not immerse the appliance, power cord, or plug in water or any liquid. If the appliance falls into water, unplug it immediately and do not reach into the water. If the power cord is damaged, it must be replaced by the manufacturer, its service agent, or a similarly qualified person.

3. Professional Installation Required

Installation must comply with all applicable federal, state, and local plumbing and electrical codes, and should be performed by a qualified plumber and/or qualified technician. Improper installation may cause leaks, electric shock, product failure, or property damage, and may void the warranty. Before drilling, make sure there are no electrical wires, water pipes, or gas lines in the drilling path.

4. Cold Water Supply Only

Connect this system to a potable cold water supply only. Do not connect the unit to a hot water supply line, and do not use it with water that is microbiologically unsafe or of unknown quality without adequate disinfection before the system. For better taste and longer product life, filtered water is recommended. Do not dispense or heat any liquid other than potable water, including juice, syrup, alcohol, flammable liquids, or chemicals.

5. Water Pressure Requirement

The water supply pressure must be within the specified range of 2.9–87psi / 0.02–0.6 MPa. If the water pressure exceeds the maximum limit, install a pressure-reducing valve. If water hammer conditions exist, install a water hammer arrester. A dedicated shut-off valve on the cold water supply line is recommended.

6. Pressure Relief Valve Safety

The supplied pressure relief valve must be installed on the water inlet of the instant hot water tank. This valve is a required safety component and must not be omitted. During heating, water may drip from the pressure relief hole; this is normal pressure release. Do not block, remove, adjust, or modify the valve, and do not operate the unit without this valve installed.

7. Ventilation and Outlet Restriction Warning

Do not block the vent, steam outlet, or water outlet, and do not install any shut-off valve, check valve, or closed valve device at the hot water outlet of the main unit. Do not modify the water outlet, tubing, or faucet connection. Blocked ventilation or restricted outlet flow may cause overheating, malfunction, leakage, or product damage.

8. Fire Hazard

To reduce the risk of fire, do not store rags, paper, aerosol cans, gasoline, or other flammable vapors or liquids near the unit. Do not use open flames, torches, or high-temperature tools near plastic tubing, fittings, or the appliance.

9. Leak Hazard

Regularly inspect the dispenser, tubing, fittings, and connections for leakage. If leakage is found, shut off the water supply immediately and disconnect power. In locations where water leakage could cause property damage, a drain pan connected to an appropriate drain, or equipped with a leak detector, is recommended. Make sure all tubing is fully inserted and secured with the supplied locking clips.

10. Dry-Heating Warning

Do not power on or heat the unit before the internal tank is completely filled with water. During first-time use, the faucet must dispense water smoothly before the power is turned on. Heating an empty tank may cause dry-heating failure, short circuit, electric leakage, or permanent product damage.

11. Maintenance Safety

Before cleaning, servicing, moving, or draining the unit, always disconnect the power, shut off the water supply, and allow the unit to cool down completely. Do not disassemble or repair the unit by yourself.

12. Freezing Protection

Protect the unit from freezing. Do not install the product outdoors or in areas exposed to freezing temperatures. If the ambient temperature may fall below 40°F / 4°C, shut off the water supply, disconnect power, and drain the unit and tubing. Damage caused by freezing is not covered by warranty.

13. Normal Operating Sound

A slight boiling, heating, clicking, or water movement sound may occur during heating. This is normal and indicates that the unit is operating.

Package Contents

For SKU B25AU-FHB System

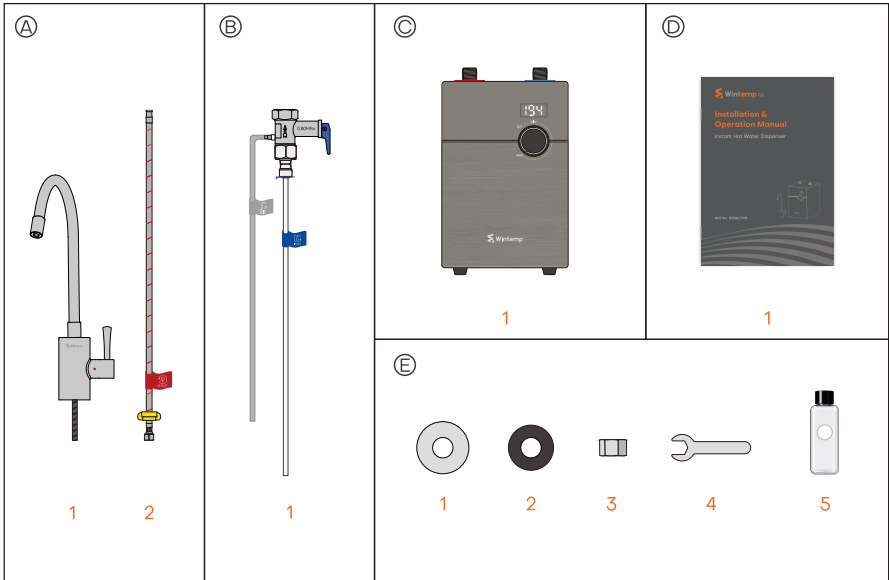

No	Part Name & Quantity
A	A1: Single-function hot water faucet x1 A2: G1/2 SUS braided hose x1
B	B1: Pressure relief valve assembly x1 (includes one 1/4" white PE tube and one gray drip tube)
C	C1: Instant hot water tank x1
D	D1: User manual x1
E	E1: Stainless steel washer x1 E2: Rubber gasket x1 E3: Hex nut x1 E4: Wrench x1 E5: Pressure Relief Drain Bottle x1

Complete Assembly View

The complete system includes the faucet, instant hot water tank, water supply tubing, pressure relief valve assembly, optional water filter, quick-connect fittings, locking clips, and power connection.

Before installation, identify each connection point and confirm that all tubing can be routed without kinks or tension.

- Cold water supply
- Optional water filter outlet
- Pressure relief valve assembly
- Water inlet of the hot water tank
- Hot water outlet of the hot water tank
- Faucet hot water tube
- Power cord (Length: approximately 47.2 in / 120 cm.)

For SKU **B25AU-FHB** system

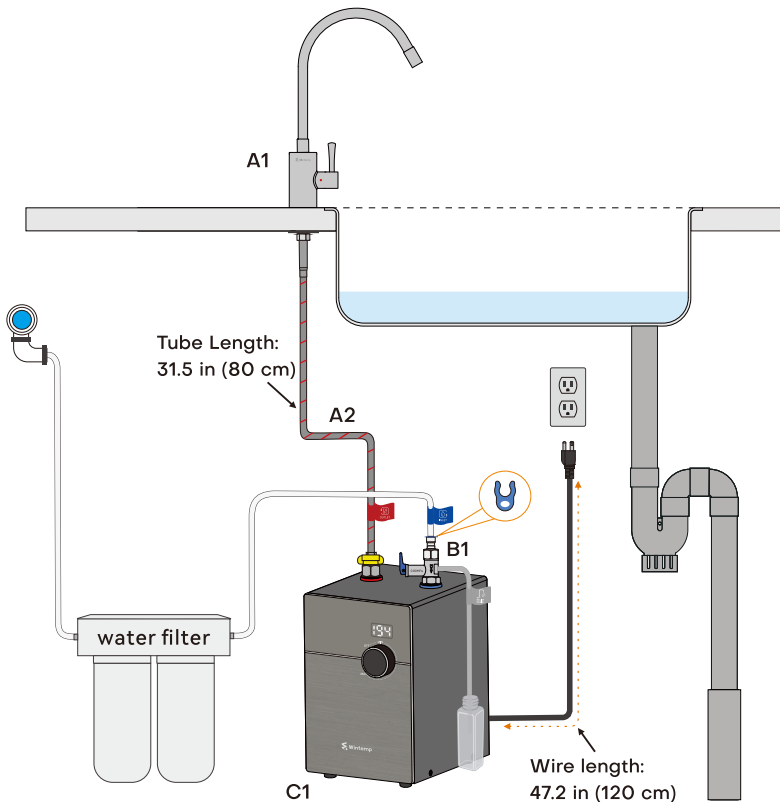

Technical Specifications

Product Name	Hot Water Dispenser Tank
Model No.	B25AU
Rated Voltage	110-127V~
Rated Frequency	60 Hz
Rated Power	Low setting 750W / High setting 1300W
Maximum Outlet Water Temperature	194°F / 90°C
Operating Environment Temperature	32-140°F / 0-60°C
Capacity	0.66gal / 2.5L
First Heating Time	Approx. 10 minutes at 1300W; Approx. XX minutes at 750W Actual heating time may vary depending on the selected power setting and inlet water temperature.
Inlet Water Pressure Range	2.9-87psi / 0.02-0.6 MPa
Tank Material	SUS304

Product Name	Hot Water Dispenser Faucet
Model No.	FHB
Faucet Hole Size	0.98-1.26 in / 25-32 mm
Maximum Countertop Thickness	1.57 in / 40 mm
Faucet Temperature Resistance Range	32-208°F / 0-98°C
Material	SUS304

Before Installation

Before installing the product, open the package and check the packing list to make sure all parts are included.

Make sure the installation location meets all of the following requirements before beginning installation.

- The product must be installed indoors only.
- The under-counter space must provide adequate room for the tank, tubing, and power cord.
- The unit must be installed upright on a stable, flat surface.
- The unit must be installed near a grounded electrical outlet, and the outlet should remain accessible after installation.
- Do not install the product in direct sunlight, outdoors, near high-temperature sources, or where it may be struck, crushed, or damaged by stored items.
- Do not use rigid piping. Use the supplied tubing and compatible plastic water lines.
- Make sure all tubing can be routed without kinks, twisting, pinching, or sharp bends.

Installation Guide

A. Faucet Installation

Step 1: Drill the Faucet Hole

If your countertop already has a hole, make sure the diameter is between 0.98 in / 25 mm and 1.26 in / 32 mm. If you need to drill a new hole, use the correct-sized drill bit to create a hole within this range. The countertop thickness must not exceed 1.57 in / 40 mm; otherwise, the faucet cannot be properly installed.

Step 2: Insert the Faucet Body

Place the faucet body into the prepared hole from above the countertop. Make sure the faucet is facing the correct direction and sits flat on the countertop surface.

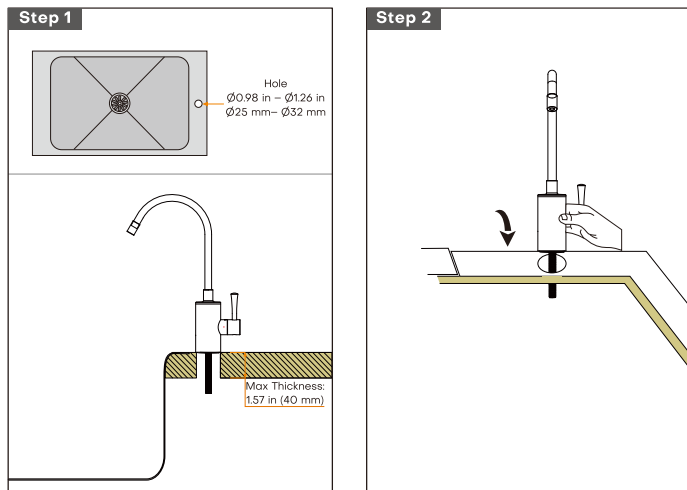

Step 3–Step 4: Install the Rubber Gasket

Place the faucet body in the correct mounting position. From underneath the countertop, slide the black rubber gasket onto the threaded pipe and align it with the corresponding mounting hole. Gently push the gasket upward until it sits flush against the underside of the countertop.

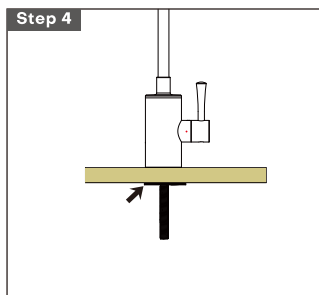
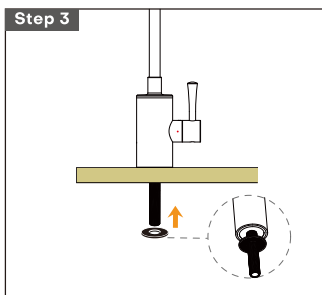

Step 5–Step 6: Install the Stainless Steel Washer

Slide the stainless steel washer onto the threaded pipe from underneath the countertop and push it upward until it contacts the rubber gasket.

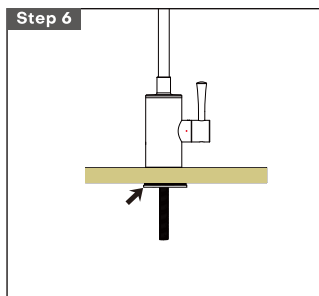
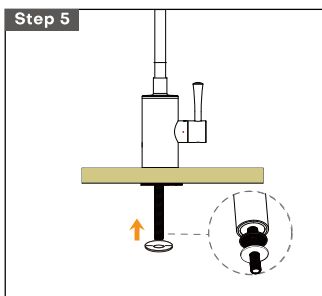

Step 7–Step 8: Tighten the Hex Nut

Thread the hex nut counterclockwise onto the threaded pipe. Use the supplied wrench to tighten the nut upward until it is firmly secured against the washer and gasket.

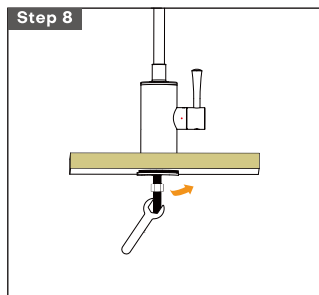
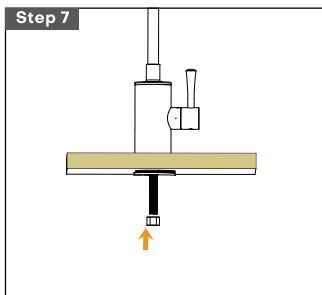

Step 9–Step 10: Connect the Outlet Braided Hose

Thread the braided hot water outlet hose counterclockwise onto the hot water inlet connector at the bottom of the faucet, then tighten it securely.

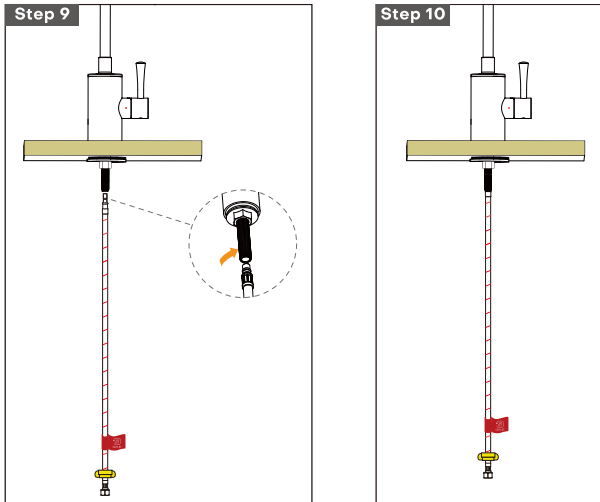

B. Hot Water Dispenser Installation

Step 11: Position the Hot Water Tank

Place the hot water tank under the sink in a stable, upright position. Make sure the tank is close enough to the faucet and power outlet, the power cord is not stretched, the tank is not touching hot pipes or sharp objects, tubing can be connected without bending or twisting, and the unit can be accessed for future maintenance.

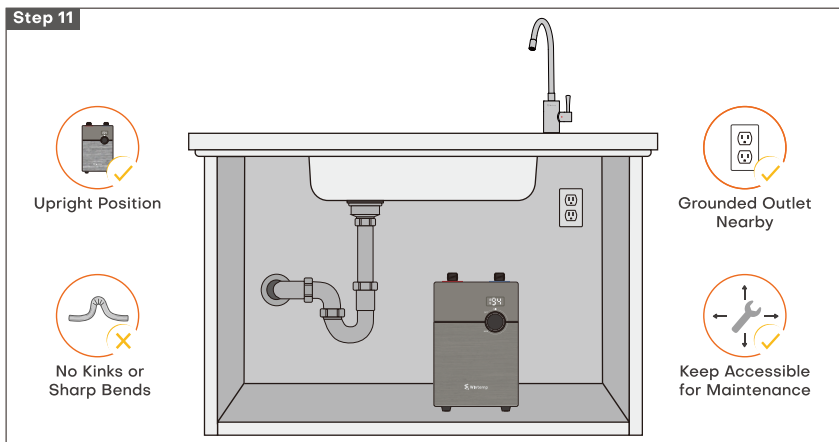

Step 12-Step 13: Install the Pressure Relief Valve

Install the supplied pressure relief valve assembly on the water inlet of the instant hot water tank, then tighten it securely. This valve is a required safety component and must not be omitted.

Peel off the adhesive backing from the Pressure Relief Drain Bottle, then attach the bottle to the side of the unit, the cabinet door, or the cabinet side panel.

Insert the gray drip tube into the opening of the bottle and make sure the tube remains securely positioned and is not kinked, blocked, or pulled out.

During heating, a small amount of water may drip into the bottle. This is normal pressure release. Check the bottle regularly and empty it before it becomes full to prevent overflow and possible property damage. Do not block, remove, adjust, or modify the pressure relief valve.

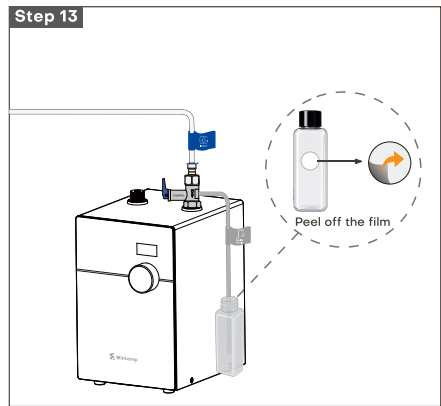
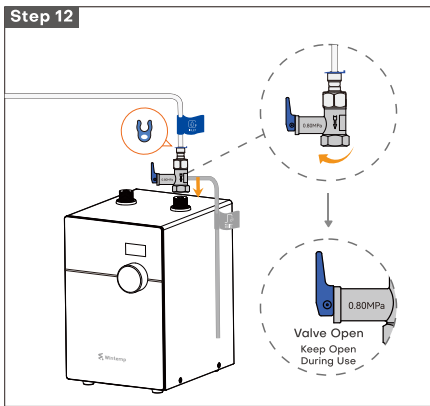

Step 14-Step 15: Connect the Water Supply

The pressure relief valve comes with one pre-installed PE tube. Make sure the PE tube is fully inserted, secured with the supplied blue locking clip, and locked in place.

Connect the water supply PE tube to the filter outlet. If no water filter is used, connect it directly to the water supply fitting.

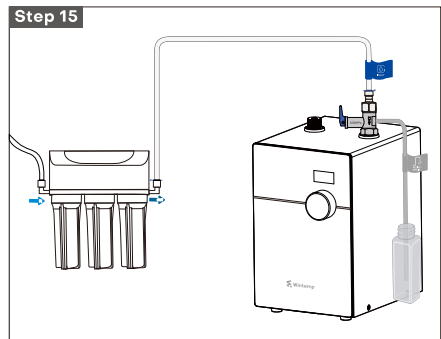
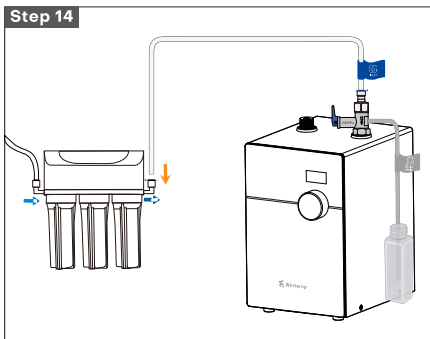

Step 16: Connect the Faucet Hot Water Tube to the Tank Outlet

Thread the faucet's hot water outlet tube connector nut onto the dispenser's "Hot Water Outlet" port. Then, use the included G1/2 plastic wrench to tighten the hex nut until it is securely fastened. Make sure the water tube is securely tightened, and confirm that it is not kinked, twisted, pinched, or pulled too tightly. The tube must allow smooth water flow from the tank to the faucet.

C. Final Connection Check

Step 17: Check All Connections Before Use

Before turning on the water or power, confirm that the faucet is firmly fixed to the countertop, the pressure relief valve is installed on the tank water inlet, the cold water supply tube is connected to the tank inlet, and the faucet hot water tube is connected to the tank outlet. Also confirm that all tubes are fully inserted or securely tightened, all blue locking clips are installed where required, and no tube is kinked, twisted, pinched, or blocked.

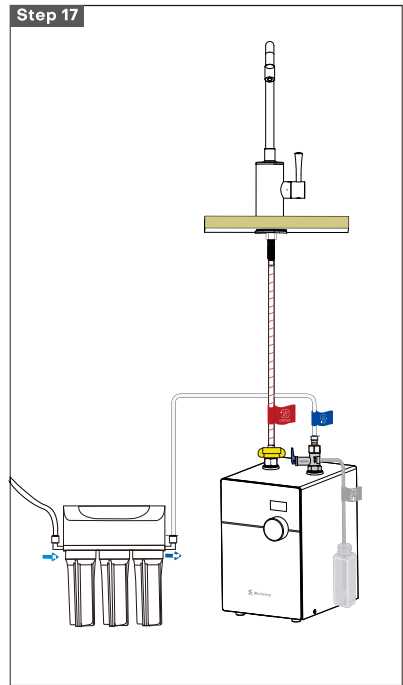
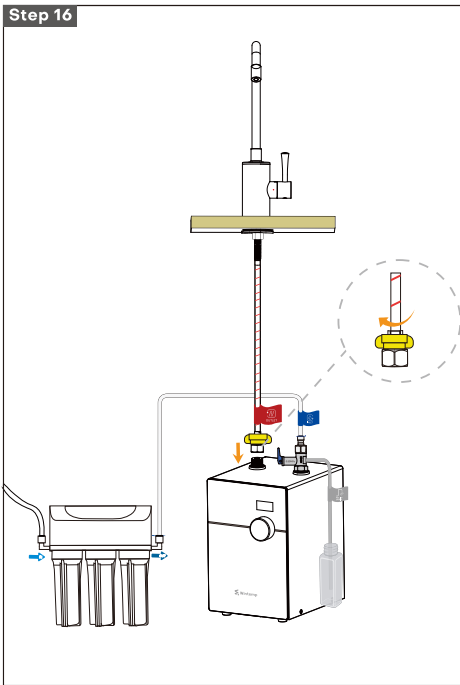

First-Time Use Instructions

For first-time use, the internal tank must be filled with water before power is turned on.

- Make sure the power is OFF and the unit is unplugged.
- Open the cold water supply valve.
- Open the hot water faucet.
- At first, no water may come out because the internal tank is empty.
- Wait approximately 2 minutes. Air and water may come out intermittently.
- Close the faucet.
- Check all fittings and tubing for leaks, including the pressure relief valve assembly.
- Plug the unit into a grounded outlet.
- Turn on the rear rocker switch.
- Rotate the front control knob to the desired heating position.
- The display will show the current tank water temperature.

Important: Never turn on the power before water flows smoothly from the faucet. Heating an empty tank may cause dry-heating failure and product damage.

Function & Operation Guide

1. Power Control (Fig 1)

The unit has a rear rocker switch located at the upper rear side of the appliance. The rocker switch allows the user to select 750W low-power heating, OFF, or 1300W high-power heating. Customers may select the heating power according to their needs.

2. Turning the Unit On

Make sure the tank is filled with water before turning on the unit. Press the rear rocker switch to select 750W or 1300W (Fig 1). Rotate the front control knob clockwise from OFF to the desired temperature setting (Fig 2). The unit will begin heating automatically. Turn the knob toward MAX only when the highest water temperature is desired (Fig 2). The display shows the current tank water temperature.

3. Heating Operation

After the unit is turned on, the heating system starts automatically. When the tank water temperature reaches the selected setting, heating stops automatically. When hot water is dispensed and the tank water temperature drops, the unit automatically reheats to the selected setting.

Note: At higher altitudes, water boils at lower temperatures. The actual boiling behavior may vary depending on altitude and local conditions.

4. Turning the Unit Off

To turn the unit off, rotate the front knob counterclockwise to OFF (Fig 2) and press the rear rocker switch to the OFF position (Fig 1). If the unit will not be used for an extended period, unplug the power cord and shut off the water supply.

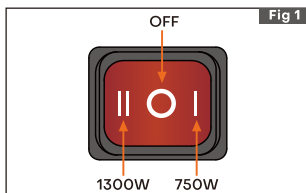

Faucet Use Guide

Single-Function Faucet: FHB

The single-function faucet dispenses hot water only. To dispense hot water, place a cup or container under the faucet outlet, carefully operate the faucet handle, and close the handle to stop water flow.

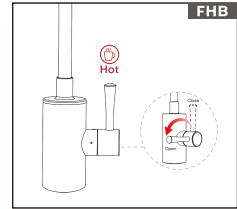

Maintenance

1. Cleaning the Exterior

Regularly wipe the outside surface of the unit and faucet with a soft, damp cloth. Do not use corrosive cleaners, abrasive brushes, steel wool, strong solvents, or harsh chemical cleaners, as these may damage the finish.

2. Regular Inspection

Inspect the system regularly. Check the faucet base, hot water outlet connection, water inlet connection, pressure relief valve assembly, quick-connect fitting, blue locking clips, tubing, filter connections, and power cord and plug. If leakage, corrosion, damage, or abnormal operation is found, stop using the product, shut off water, disconnect power, and contact customer service.

3. Pressure Relief Valve Maintenance

The pressure relief valve is required for safe operation. During heating, a small amount of water may drip into the Pressure Relief Drain Bottle. This is normal pressure release. Check the bottle regularly and empty it if water accumulates. Make sure the gray drip tube remains securely inserted in the bottle and is not kinked or blocked. Do not block, remove, adjust, or modify the pressure relief valve. If dripping continues when the unit is not heating, shut off the water supply, disconnect power, and contact customer service.

4. Filter Maintenance

If a filter is installed, replace the filter cartridge according to the filter manufacturer's recommended schedule. Replace the filter sooner if water flow becomes noticeably reduced, water taste changes, water odor appears, or the filter has reached its rated service life. Failure to replace the filter may reduce performance and may cause pressure drop, leakage, or poor water quality.

5. Descaling

Mineral scale may build up inside the tank depending on water quality. To reduce scale buildup, use filtered water when possible and avoid using hard water directly. Drain and clean the system periodically if local water hardness is high. If heating efficiency drops or noise increases, descaling may be required. Do not use unauthorized descaling chemicals unless approved by WINTEMP.

6. Preparing for Extended Non-Use

If the unit will not be used for an extended period, turn the front knob to OFF, turn the rear rocker switch to OFF, unplug the power cord, shut off the water supply valve, allow the unit to cool completely, open the faucet to release pressure, drain water from the tank and tubing if possible, and keep the unit dry and protected from freezing.

7. Seasonal Storage / Freezing Conditions

If the appliance may be exposed to temperatures below 40°F / 4°C, disconnect power, shut off the water supply, open the faucet, and drain water from the system. Remove or drain filter cartridges if installed, and store the unit in a dry, frost-free location. Damage caused by freezing is not covered by warranty.

Troubleshooting Guide

Symptom	Likely Reason	Corrective Action
No hot water	The unit may not have power, the rear rocker switch or front knob may be OFF, the circuit breaker or GFCI outlet may have tripped, the tank may not be fully filled, or overheat protection may have activated.	Make sure the unit is plugged into a grounded outlet, reset the GFCI if needed, check the circuit breaker, select 750W or 1300W on the rear switch, rotate the front knob to the desired temperature, and confirm that water flows smoothly from the faucet. If the issue continues, disconnect power and contact customer service.
Water is not hot enough	The temperature setting may be too low, the hot water supply may have been used heavily, the unit may need more reheating time, local altitude may affect boiling temperature, or scale may have built up inside the tank.	Rotate the knob to a higher setting, wait approximately 5–10 minutes for reheating, dispense water for several seconds to refill the tank with fresh water, and descale the unit if scale buildup is suspected. Contact customer service if performance does not improve.
No water flows from the faucet	The water supply valve may be closed, tubing may be kinked or pinched, the filter cartridge may be clogged, the faucet outlet may be blocked, a quick-connect fitting may not be fully inserted, or the valve/tee connector may be blocked.	Open the water supply valve fully, check tubing for kinks, replace the filter cartridge if installed, clean the faucet outlet if applicable, fully reinsert tubing, secure all locking clips, and check the pressure relief valve assembly and fittings.
Water flow is weak	Supply pressure may be low, the filter cartridge may be clogged, tubing may be kinked, debris may be trapped in the faucet outlet, or the shut-off valve may be partially closed.	Confirm that supply pressure is within the required range, fully open the water supply valve, replace the filter cartridge if needed, clean the faucet outlet, and check all tubing and fittings.
Water drips from the faucet outlet	Water may expand during heating, supply pressure may be unstable, the outlet or vent path may be restricted, or the faucet handle may not be fully closed.	Occasional dripping during heating may occur due to expansion. Make sure the faucet is fully closed, check that the outlet tube is not blocked, fully open the water supply valve, clean the faucet outlet, and contact customer service if dripping continues.

Symptom	Likely Reason	Corrective Action
Water drips from the pressure relief valve	Small drips from the pressure relief hole during heating are normal and indicate pressure release. Continuous dripping when the unit is not heating may indicate abnormal pressure or valve issues.	Do not block, remove, adjust, or modify the valve. If dripping continues when the unit is not heating, shut off the water supply, disconnect power, allow the unit to cool, and contact customer service.
Water leaks under the sink	Tubing may not be fully inserted, a locking clip may be missing, a nut or fitting may be loose, tubing may be damaged, water pressure may be too high, or the pressure relief valve assembly may be installed incorrectly.	Shut off water immediately and disconnect power. Recheck all connections, fully insert tubing, install all blue locking clips, tighten fittings carefully, replace damaged tubing, and install a pressure-reducing valve if water pressure is too high.
Unusual noise during heating	A slight boiling or heating sound is normal. Louder noise may be caused by air in the tank or tubing, mineral scale buildup, or water pressure fluctuation.	Open the faucet several times to purge air, descale the unit if scale buildup is suspected, and stop using the product and contact customer service if loud or abnormal noise continues.
Water has unusual taste, odor, or color	New tubing or tank components may need flushing, the filter cartridge may need replacement, the incoming water quality may be poor, or scale/contamination may be present inside the system.	Flush the system before first use, replace the filter cartridge if installed, check the incoming water source, drain and refill the tank, and stop using the product and contact customer service if discoloration remains.

Error Display:

When the system encounters a failure, the fault code will be displayed on the screen as follows:

Error	Possible Reason	Solution
E3	Tank Temperature Sensor Fault.	Power off the unit, allow it to cool, then restart it. If the fault code remains, stop using the unit and contact WINTEMP Customer Support for service assistance.

Important Use Notes

- This product is intended for indoor household use only.
- This product is not intended for commercial or industrial use.
- Do not modify the system.
- Use only supplied or approved parts and accessories.
- Do not connect this tank to an ordinary faucet or incompatible dispenser.
- Do not install a shut-off valve at the hot water outlet.
- The pressure relief valve must be installed on the tank water inlet and must not be removed, blocked, adjusted, or modified.
- Do not operate the unit continuously at boiling condition for extended periods.
- Regularly inspect the system for leakage or corrosion.
- Replace the unit when necessary, as any hot water tank has a limited service life.

Warranty & Service Information

For warranty service, technical support, or replacement parts, please contact WINTEMP customer service.

When requesting service, please provide the product model number, purchase date, installation date if available, description of the issue, photos or videos of the installation and problem if available, and proof of purchase if required.

WINTEMP may make improvements or changes to product specifications, components, and manual content without prior notice.



To obtain the benefit of this warranty, please email
support@wintempshop.com.

We will address your issue as soon as possible!

Our official website address

www.wintempshop.com

Install QR code

